



ORIGINAL RESEARCH PAPER

Community behavior for mathematical model of coronavirus disease 2019 (COVID-19)

M. Ramli^{1*}, M. Mukramati¹, M. Ikhwan² H. Hafnani¹

¹Department of Mathematics, Universitas Syiah Kuala, Banda Aceh 23111, Indonesia

²Graduate School of Mathematics and Applied Sciences, Universitas Syiah Kuala, Banda Aceh 23111, Indonesia

ARTICLE INFO

Article History:

Received 13 May 2021
Revised 24 July 2021
Accepted 26 August 2021

Keywords:

Basic reproduction number
Coronavirus disease 2019
(COVID-19)
Equilibrium point
Mask
Physical distancing

ABSTRACT

BACKGROUND AND OBJECTIVES: The spread of COVID-19 is very fast because it is transmitted from human to human. Non-pharmaceutical control is one of the important actions in reducing the spread of COVID-19, such as the use of masks and physical distancing. This study aims to model COVID-19 by incorporating people's habits as a non-pharmaceutical preventive measure. The model formed emphasizes the importance of preventing with masks and physical distancing. The implication of this action is that the infected population is decreasing, resulting in less interaction between the susceptible and the infected. In this case, the virus has not vanished from the community, but the use of masks in certain populations or subpopulations is lower than before, which can reduce mask waste in the environment

METHODS: This study expands on a previous MERS-CoV research model using the susceptible-exposed-infected-quarantine-recovery model by incorporating behavioral control, specifically the use of masks and physical distancing as preventive measures. The susceptible population that interacts with the carrier/exposed and infected population is used to calculate mask use. The susceptible population was divided into two subpopulations based on their willingness to wear masks. The following breakthrough is the application of the same system to the infected population, which is required to wear masks at all times during their self-isolation period. The model-generated equation system is a nonlinear system of differential equations. The developed model is examined by determining the equilibrium point and the basic reproduction number.

FINDINGS: The model resulted an asymptotically stable disease-free equilibrium and endemic equilibrium. The disease-free stability is only examined if the compliance with physical distancing exceeds 0.55 and the compliance with the use of distancing exceeds 0.55. This compliance condition resulted in a decrease in basic reproduction number ranging from 0.48 to 0.07. The endemic stability is only investigated if compliance with physical distancing is 0.1 and compliance with use of distancing is 0.2. The endemic condition can arise if masks and physical separation are not used. Physical distancing compliance and mask use have values less than 0.1 and 0.2, respectively

CONCLUSION: The analysis of the equilibrium points and basic reproduction numbers, show that increasing compliance in carrying out the health protocol measures of physical distancing and mask use causes a decrease in the spread of COVID-19, so that the disease will disappear over time. Meanwhile, ignoring health protocols has an effect on the long existence of the virus in the community.

DOI: [10.22034/gjesm.2022.02.01](https://doi.org/10.22034/gjesm.2022.02.01)

©2022 GJESM. All rights reserved.



NUMBER OF REFERENCES

36



NUMBER OF FIGURES

4



NUMBER OF TABLES

4

*Corresponding Author:

Email: marwan.math@unsyiah.ac.id

Phone: +62 813-9766-8376

ORCID: [0000-0003-1225-9063](https://orcid.org/0000-0003-1225-9063)

Note: Discussion period for this manuscript open until July 1, 2022 on GJESM website at the "Show Article."

INTRODUCTION

The world is currently dealing with a pandemic of a mysterious pneumonia disease known as Coronavirus Disease 2019 (COVID-19), which was discovered in December 2019 in Wuhan, Hubei province, China. COVID-19 has rapidly spread to all other countries around the world (Harapan et al., 2020; WHO, 2021a). COVID-19 spreads quickly because the virus is transmitted from person to person via droplets that come out when talking, coughing, or sneezing, as well as direct contact with infected individuals (Eikenberry et al., 2020). Based on this, the best way to limit the spread of COVID-19 cases is to avoid direct contact between humans (Soewono, 2020). Several steps have been taken to reduce human-to-human contact and prevent the spread of the COVID-19 virus. Lock downs (staying at home) have been imposed by governments all over the world as the primary and most effective means of reducing human contact. Other measures include travel restrictions (Wilder-Smith and Freedman, 2020), hand hygiene (washing hands) (Lin et al., 2020), isolation, physical distancing (Chintalapudi et al., 2020), avoiding public places or crowds, closing schools and offices, and wearing face masks (Li and De Clercq, 2020). Lock down activities (staying at home) can help to reduce the spread of COVID-19, but it will cause the economy to fall and a crisis to occur. As a result, governments in various countries that have implemented lockdown measures have been forced to lift the restrictions and allow people to resume their normal activities while still adhering to health protocols. Community behavior should adhere to applicable health protocols, such as avoiding public places or crowds (Garnett et al., 2021), physical distancing (Sasmitha et al., 2020), hand hygiene (washing hands), and wearing face masks (Tran et al., 2020). A person who has been exposed to COVID-19 will not develop symptoms right away because the severe acute respiratory syndrome coronavirus 2 (SARS-Cov-2) virus has an incubation period after entering the human body. The SARS-Cov-2 virus has an average incubation period of 5.1 to 5.8 days, and symptoms appear after 11.5 to 15.6 days. If a person becomes infected with the virus, he or she must self-isolate for 14 days due to the virus's incubation period (Laeur et al., 2020). Infected patients' initial symptoms, which range from flu and cough to chronic phase, can result in shortness of breath, acute

complications, and even death (Phan et al., 2020). According to (WHO, 2021a), 85% of positive cases infected with COVID-19 have mild symptoms or do not cause any symptoms at all, but they can still transmit the virus to others. According to the most recent WHO announcement (WHO, 2021b), the SARS-Cov-2 virus, which causes COVID-19 disease, can spread through the air produced by infected individuals' aerosol production. According to Arslan et al. (2020), droplets that come out of infected individuals within a certain distance range (1 m) can enter the mucosal surface, so that face-to-face conversation, coughing, sneezing, and breathing can cause the spread of droplets from the respiratory tract. The droplets will combine to form an aerosol, which will spread over a long distance (> 1 m) and last for a long time in the environment. The SARS-Cov-2 virus can also survive in aerosols for 3 hours and is even more stable when attached to plastic (72 hours), steel surfaces (48 hours), copper (4 hours), and cardboard (24 hours) (Doremalen et al., 2020). As a result, WHO (2020a) stated that one of the steps to prevent the spread of COVID-19 is to use masks, particularly in public places where physical distancing measures are not possible. However, the use of masks must be part of a comprehensive COVID-19 prevention strategy that includes other health protocols. The use of masks is widely believed to prevent droplets from escaping from infected individuals and carriers. Based on this, it makes sense to recommend the use of masks for vulnerable individuals in order to avoid infection (MacIntyre et al., 2021). Masks serve a dual purpose: if worn by susceptible individuals, they provide protection against infectious or non-infectious diseases transmitted by infected individuals, and if worn by infected individuals, they provide source control against disease transmission or do not transmit disease to other individuals (Lo et al. 2021; Bagepally et al., 2021). Surgical masks reduce *P. Aeruginosa*-infected aerosols produced by coughing by more than 80% in cystic fibrosis patients (Driessche et al., 2015). According to the findings of Stockwell et al. (2018), N95 masks outperform surgical (medical) masks. Eikenberry et al. (2020) estimate that the efficiency of cloth masks is between 20% and 80%, and possibly higher (well made and tightly fitted and made of good material). For surgical masks, the percentage ranges from 70% to 90%, while for N95

masks, the percentage ranges from 95% to 100%. Because non-medical masks are more commonly used than other types of masks by the general public, understanding the characteristics of non-media masks that are suitable for use to protect themselves from COVID-19 is critical. According to the WHO (2020b), non-medical masks should have three layers: 1) an innermost layer of a hydrophilic material (such as cotton or cotton blends); 2) an outer layer of a hydrophobic material (such as polypropylene, polyester, or a combination of both) that can limit contamination from outside penetrating the wearer's nose and mouth; 3) a hydrophobic middle layer made of a synthetic non-woven material such as polypropylene or cotton lining that can improve filtration or retain droplets. As time passes, countries around the world continue to struggle against COVID-19, and governments continue to encourage their citizens to wear masks when visiting public places or crowds in order to be protected. This has resulted in the widespread use of masks all over the world (Lyu *et al.*, 2020). Each month, the WHO estimates that nearly 89 million procedural masks will be required to control COVID-19 (WHO, 2021a). According to a press conference study on the Control Mechanism of the State Council of China in 2020, approximately 468.9 tonnes of medical waste are generated every day as a result of COVID-19. In Jakarta, Indonesia, however, it was discovered that the amount of medical waste had reached 12,740 tons approximately 60 days after people were first infected with the corona virus (Kojima *et al.*, 2020). The use of masks is indeed critical in order to protect individuals from COVID-19, but the increased use of masks has resulted in an increase in mask production. As a result, new environmental challenges emerge, such as the growing accumulation of medical mask waste. If the virus can be eradicated in the community, the use of masks can be reduced, potentially reducing mask waste in the environment. This study is based on the development of a mathematical model by adding community behavior as a non-pharmaceutical preventive measure (using masks and physical distancing) as well as having quarantine classes as a place to treat diseases that can minimize the spread of COVID-19. In this study, the susceptible-exposed-infected-quarantine-recovery (SEIQR) model was used by separating the susceptible and infected population into two subpopulations, respectively. There are

susceptible subpopulation not using masks (S_1), the susceptible subpopulation using masks (S_2), the infection subpopulation not using masks (I_1) and the infection subpopulation using masks (I_2). The addition of a quarantine population to the model is the same as that done by Mandal *et al.* (2020). Based on the motivation above, this study aims to model COVID-19 by including community behavior (adherence to using masks and physical distancing) in the SEIQR model as a non-pharmaceutical preventive measure. This study is simulated at the Modeling and Simulation Laboratory, Department of Mathematics, Syiah Kuala University, Indonesia in 2021.

MATERIALS AND METHODS

This study expands on the Middle East Respiratory Syndrome Coronavirus (MERS-CoV) distribution model developed by Manaqib *et al.* (2019), in which the MERS-CoV model is an SEIR type model that divides the population into four populations: susceptible, exposed, infected, and recovered. To create the SEIQR model, the SEIR model was modified by incorporating a new population class, quarantine (Q). Several non-pharmaceutical controls, such as mask use and physical distancing, were also added to reduce the spread of COVID-19. Each susceptible and infected population is subdivided into two subpopulations. As a result, the SEIQR's five populations are divided into two susceptible subpopulations, one exposed population, two infected subpopulations, one quarantine population, and one recovery population. The total population at time t is denoted as $N(t)$, and there are seven population/subpopulations: susceptible individuals who do not use masks ($S_1(t)$), susceptible individuals who do use masks ($S_2(t)$), exposed individuals ($E(t)$), infected individuals who do not use masks ($I_1(t)$), infected individuals who use masks ($I_2(t)$), quarantine individuals ($Q(t)$), and recovery individuals ($R(t)$). With the total population studied is defined using Eq. 1.

$$N(t) = S_1(t) + S_2(t) + E(t) + I_1(t) + I_2(t) + Q(t) + R(t) \quad (1)$$

The birth and death rates of individuals in the subpopulation are assumed to be equal in this model (μ). Newborns will be included in the subpopulations of susceptible individuals who do not use masks S_1 . In Susceptible S_2 and infected I_2 who use masks, all

of whom are considered uninfected and COVID-19 free. If susceptible S_2 and infected I_2 people who wear masks stop wearing them, they will be included in the subpopulation of susceptible S_1 and infected I_1 people who did not wear masks, and vice versa. Furthermore, if susceptible S_1 and infected I_1 individuals do not take physical distance measures, they have the potential to become infected and infect others, making them the exposed E . Individuals in the quarantine subpopulation Q have been determined to be unable to transmit the disease and are receiving treatment. Individuals who have been exposed to COVID-19 carry the SARS-Cov-2 virus but have not transmitted it. Individuals who have been exposed E and infected I_1, I_2 can then be identified as having a SARS-CoV2 virus in their bodies using rapid tests, antigens, and swabs, and they are added to the quarantine individual sub-population Q . Quarantine individuals are people who have tested positive for COVID-19 via rapid, antigen, or swab tests, and quarantine facilities are places of care for people who have tested positive for COVID-19 via rapid, antigen, or swab tests. If any quarantined individuals recover from the disease, they will be added to the recovered sub-population R . Individuals infected I_1, I_2 can recover naturally without disease treatment and are

classified as part of the recovered subpopulation R . The recovery population R can be re-infected, but not to population I . The re-infected path is R to S with the number regulated by the reinfected parameter. Death occurs only naturally in each populations/subpopulations. Based on this, a mathematical model diagram of the spread of COVID-19 and the Eq. 1 are obtained in Fig. 1.

The non-linear differential equation of Fig. 1 is defined using Eqs. 2 to 8.

$$\frac{dS_1}{dt} = \mu N + \kappa_1 R + u_2 S_2 - u_1 S_1 - \beta(1-\varepsilon)S_1 I_1 - \mu S_1 \quad (2)$$

$$\frac{dS_2}{dt} = \kappa_2 R + u_1 S_1 - u_2 S_2 - \mu S_2 \quad (3)$$

$$\frac{dE}{dt} = \beta(1-\varepsilon)S_1 I_1 - \delta E - \alpha E - \mu E \quad (4)$$

$$\frac{dI_1}{dt} = \delta E + u_2 I_2 - u_1 I_1 - \sigma I_1 - \eta I_1 - \mu I_1 \quad (5)$$

$$\frac{dI_2}{dt} = u_1 I_1 - u_2 I_2 - \sigma I_2 - \eta I_2 - \mu I_2 \quad (6)$$

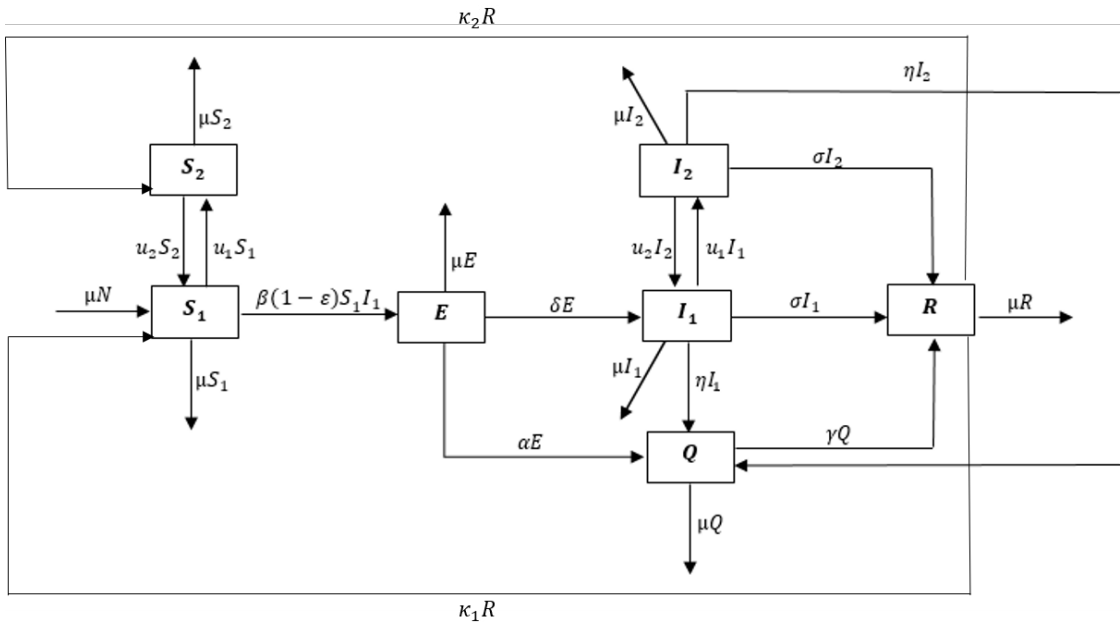

Fig. 1: Diagram of the process of spreading COVID-19 with the use of masks and physical distancing

$$\frac{dQ}{dt} = \alpha E + \eta I_1 + \eta I_2 - \gamma Q - \mu Q \quad (7)$$

$$\frac{dR}{dt} = \sigma I_1 + \sigma I_2 + \gamma Q - (\kappa_1 + \kappa_2 + \mu) R \quad (8)$$

The parameter $\beta(1-\varepsilon)$ in Eqs. 2 and 4 quantifies the extent to which susceptible individuals S_1 will be included in the exposed subpopulation E due to a lack of physical distancing measures. The level of transmission of COVID-19 disease is denoted by β , and $0 < \varepsilon < 1$ is the proportion of people who physically distance themselves from others. The parameter δ represents the number of people who have been exposed to the SARS-CoV2 virus during its incubation period and are included in the subpopulation of infected people who are not wearing a mask, whereas the parameter α represents the number of people who have had a positive rapid, antigen, or swab test and are included in the quarantine subpopulation to receive treatment. η is the proportion of infected people who receive disease treatment and are included in the quarantine subpopulation. In Eqs. 2, 3, 5 and 6, $0 < u_1 + u_2 < 1$ is the level of individuals who use masks and do not use masks. Susceptible S_1 and infected I_1 individuals who begin implementing the health protocol using masks will be included in the subpopulation of susceptible S_2 and infected I_2 individuals as u_1 . In turn, susceptible S_2 and infected I_2 individuals who begin to discontinue the use of masks in the health protocol will be included in the subpopulation of susceptible S_1 and infected I_1 individuals as u_2 . Furthermore, parameter γ in Eq. 7 denotes infected and exposed individuals who recovered by receiving treatment in the quarantine subpopulation and were then included in the cured subpopulation R , whereas infected individuals who recovered naturally without receiving treatment were included in the cured subpopulation R as much as σ (Eq. 8). Eqs. 2 to 8 can be simplified by forming the proportion of the number of individuals in a subpopulation with the total population, which is expressed using Eq. 9.

$$s_1 = \frac{S_1}{N}, s_2 = \frac{S_2}{N}, e = \frac{E}{N}, i_1 = \frac{I_1}{N}, \quad (9)$$

$$i_2 = \frac{I_2}{N}, q = \frac{Q}{N}, r = \frac{R}{N}$$

Where, Eq. 9 is substituted into Eqs. 2 to 8, the Eqs. 10 to 16 are obtained.

$$\frac{ds_1}{dt} = \mu + \kappa_1 r + u_2 s_2 - u_1 s_1 - \beta(1-\varepsilon) s_1 i_1 - \mu s_1 \quad (10)$$

$$\frac{ds_2}{dt} = \kappa_2 r + u_1 s_1 - u_2 s_2 - \mu s_2 \quad (11)$$

$$\frac{de}{dt} = \beta(1-\varepsilon) s_1 i_1 - \delta e - \alpha e - \mu e \quad (12)$$

$$\frac{di_1}{dt} = \delta e + u_2 i_2 - u_1 i_1 - \sigma i_1 - \eta i_1 - \mu i_1 \quad (13)$$

$$\frac{di_2}{dt} = u_1 i_1 - u_2 i_2 - \sigma i_2 - \eta i_2 - \mu i_2 \quad (14)$$

$$\frac{dq}{dt} = \alpha e + \eta i_1 + \eta i_2 - \gamma q - \mu q \quad (15)$$

$$\frac{dr}{dt} = \sigma i_1 + \sigma i_2 + \gamma q - (\kappa_1 + \kappa_2 + \mu) r \quad (16)$$

The symbols of variables and parameters used in the model are summarized in [Tables 1 and 2](#).

The parameter values used in this study were derived from publicly available COVID-19 data as well as literature sources such as journals, articles, and so on. The parameter values were set to be $\delta = 0.3$ from exposed to infected individuals ([Mandal et al., 2020](#)). Individuals who have been exposed to COVID-19 will not immediately show symptoms, because the COVID-19 virus will experience an incubation period. Some studies estimate that if someone is exposed to COVID-19, they must isolate themselves for 14 days, where the average incubation period of the virus is 5.1 to 5.6 days and some start showing symptoms on days 11.5 to 15.6 ([Laeur, 2020](#)). Parameter value of recovered individuals after quarantine $\eta = 1/14$ ([Tang et al., 2020](#)). Furthermore, the parameters of exposed individuals that were included in the quarantine subpopulation $\alpha = 0.1326$ ([Resmawan et al., 2021](#)). Individuals infected with COVID-19 have a healing process against the disease by $\sigma = 0.25$ ([Mandal et al., 2020](#)). Given that the average time for infected

Table 1: COVID-19 spread model variable symbol

Symbol	Explanation
N	Total population in the system
S_1	Number of subpopulations of susceptible individuals not wearing masks
S_2	Number of subpopulations of susceptible individuals using masks
E	Number of individual subpopulations exposed
I_1	Number of subpopulations of infected individuals not wearing masks
I_2	Number of subpopulations of infected individuals wearing masks
Q	Number of quarantined individual subpopulations
R	Number of subpopulations of recovered individuals

Table 2: COVID-19 spread model parameters

Symbol	Explanation	Value	Source
μ	The birth or death rate of individuals in the population	0.002116268	Determined (Sasmitha et al., 2020)
ε	physical distancing	(0.1, 0.55, 0.9)	Assumption
u_1	Mask usage rate	(0.2, 0.55, 0.88)	Assumption
u_2	The rate of not/stopping using a mask	(0.8, 0.45, 0.12)	Assumption
β	Disease transmission rate	0.75	Determined (Zhu and Zhu, 2021)
α	The rate of individual exposed to quarantine individual	0.1326	Determined (Resmawan et al., 2021)
δ	The rate of individual is exposed to an infected individual	0.3	Determined (Mandal et al., 2020)
η	The rate of infected individuals being quarantined individuals	0.025	Determined (Eikenberry et al., 2020; Ferguson et al., 2020)
σ	The rate of infected individual recover without treatment	0.25	Determined (Mandal et al., 2020)
γ	The rate of quarantine individual recover with treatment	0.07142857142	Determined (Tang et al., 2020)
κ_1	The rate of recovered individual back to susceptible not wearing masks	1/120	Determined $\kappa_1 + \kappa_2 = 1/60$ (Batistela et al., 2021; Dwomoh et al., 2021)
κ_2	The rate of recovered individual back to susceptible wearing masks	1/120	

individuals is 7 days before dyspnea (difficulty breathing), 9 days before sepsis (complications due to life-threatening infection), and a range of 1-10 days before receiving treatment, $\gamma = 0.025$ is determined (Eikenberry et al., 2020; Ferguson et al., 2020; Eubank et al., 2020). The rate of transmission of COVID-19 disease varies greatly due to the actions taken to reduce COVID-19. The lower the level of action taken, the higher the transmission rate; we set the parameter value $\beta = 0.75$ where no preventive measures were taken so that the rate of transmission was high; the value of this parameter is taken from Zhu and Zhu (2021). Individual birth and death rates

are regarded as equal. Then, for the parameter values of physical distancing measures and mask use, there are several variations caused by the possibility of individuals in the population performing these actions: $\varepsilon = [0.1, 0.55, 0.9]$, $u_1 = [0.2, 0.55, 0.88]$, and $u_2 = [0.8, 0.45, 0.12]$.

Figure illustration

The study describes the impact of compliance with COVID-19 disease control policies such as the use of masks and physical distancing on the spread of COVID-19. This illustration involves three important parameters in COVID-19 prevention measures, $\varepsilon, u_1,$

and u_2 with the values of the three parameters being different based on the data obtained as described previously. This illustration depicts the amount of spread of COVID-19 in a population over time (in day). The illustrations performed on this model include only for asymptotically stable conditions. The illustration is obtained by substituting the parameters in Table 2, initial values of stated variables, and the parameter values ε, u_1 , and u_2 that have been set to Eqs. 10 to 16. Initial values were obtained from Indonesia's COVID-19 conditions on June 22, 2021 (Satgas, 2021), there are $s_1(0)+s_2(0)=269451481$, $e(0)=124918$, $i_1(0)+i_2(0)=13668$, $q(0)=4958$, and $r(0)=8375$.

RESULTS AND DISCUSSION

Equilibrium points

The equilibrium point is the point where each state variable does not change in value, marked by the first derivative of each variable equal to 0 (Safitri et al., 2019). The equilibrium value is obtained from every first derivative of the SEIRQ variable with the condition that it must be equal to 0. Eqs. 10 to 16 have two equilibrium points. One of the equilibrium points is the disease-free equilibrium point, where the infection will disappear from the system (infected i_1 and i_2 are disappear). The point is obtained using Eq. 17.

$$E_0(s_1^*, s_2^*, 0, 0, 0, 0, 0) \tag{17}$$

Where, $s_1^* = \frac{\mu + u_2}{\mu + u_1 + u_2}$ and $s_2^* = \frac{u_1}{\mu + u_1 + u_2}$. Another equilibrium point is the point where the infection will continue to exist in the system which is called the endemic equilibrium point. The point is obtained using Eq. 18.

$$E_1(s_1^*, s_2^*, e^*, i_1^*, i_2^*, q^*, r^*) \tag{18}$$

$$\text{Where, } s_1^* = \frac{\mu + \kappa_1 r^* + u_2 s_2^*}{\mu + u_1 + \beta(1-\varepsilon)i_1^*}, s_2^* = \frac{\kappa_1 r^* + u_1 s_1^*}{\mu + u_2}$$

$$e^* = \frac{\beta(1-\varepsilon)s_1^* i_1^*}{\delta + \alpha + \mu}, i_1^* = \frac{\delta e^* + u_2 i_2^*}{\sigma + \eta + u_1 + \mu}, i_2^* = \frac{u_1 i_1^*}{\sigma + \eta + u_2 + \mu}$$

$$q^* = \frac{\alpha e^* + \eta(i_1^* + i_2^*)}{\gamma + \mu}, \text{ and } r^* = \frac{\sigma(i_1^* + i_2^*) + \gamma q^*}{\kappa_1 + \kappa_2 + \mu}$$

The asterisk in each state variable is referred to as the optimal value obtained from the first derivative which is equated with 0.

Basic reproductive number

The basic reproduction number is one of the most important parameters in epidemiological models, and it is useful in determining the nature of disease that occurs in a population. According to Driessche and Watmough (2002), the basic reproduction number is the expected value of the number of infections per unit time caused by one infected individual case that occurs in a population at a given time. R_0 represents the basic reproduction number. R_0 can be calculated in a variety of ways, but we will use the next generation matrix. The subpopulations that will be used are those that cause disease spread (infection), namely the exposed subpopulation (E), the infected subpopulation that is not wearing a mask (I_1), the infected subpopulation that is wearing a mask (I_2), and the quarantine subpopulation (Q).

$$\frac{de}{dt} = \beta(1-\varepsilon)s_1 i_1 - \delta e - \alpha e - \mu e \tag{19}$$

$$\frac{di_1}{dt} = \delta e + u_2 i_2 - u_1 i_1 - \sigma i_1 - \eta i_1 - \mu i_1 \tag{20}$$

$$\frac{di_2}{dt} = u_1 i_1 - u_2 i_2 - \sigma i_2 - \eta i_2 - \mu i_2 \tag{21}$$

$$\frac{dq}{dt} = \alpha e + \eta i_1 + \eta i_2 - \gamma q - \mu q \tag{22}$$

Eqs. 19 to 22 can be written as $x' = \varphi(x) - \zeta(x)$, where φ is the new infection rate and ζ is the infection transition rate. Thus, the Eq. 23 is obtained.

$$x' = \begin{pmatrix} e \\ i_1 \\ i_2 \\ q \end{pmatrix}, \varphi(x) = \begin{pmatrix} \beta(1-\varepsilon)s_1 i_1 \\ 0 \\ 0 \\ 0 \end{pmatrix}, \zeta(x) = \begin{pmatrix} e(\delta + \alpha + \mu) \\ -\delta e - u_2 i_2 + i_1(\sigma + \eta + u_1 + \mu) \\ -u_1 i_1 + i_2(\sigma + \eta + u_2 + \mu) \\ -\alpha e - \eta i_1 - \eta i_2 + q(\gamma + \mu) \end{pmatrix} \tag{23}$$

Substitute the disease-free equilibrium point Eq. 17, so that the Jacobian matrix of φ and ζ is obtained as Eq. 24.

$$F = \begin{bmatrix} 0 & \frac{\beta(1-\varepsilon)(\mu+u_2)}{\mu+u_1+u_2} & 0 & 0 \\ 0 & 0 & 0 & 0 \\ 0 & 0 & 0 & 0 \\ 0 & 0 & 0 & 0 \end{bmatrix}, \quad (24)$$

$$V = \begin{bmatrix} \delta+\alpha+\mu & 0 & 0 & 0 \\ -\delta & \sigma+\eta+u_1+\mu & -u_2 & 0 \\ 0 & -u_1 & \sigma+\eta+u_2+\mu & 0 \\ -\alpha & -\eta & -\eta & \gamma+\mu \end{bmatrix}$$

The spectral radius of the matrix $K = FV^{-1}$ is the basic reproduction number (R_0). Thus, the Eq. 25 is obtained.

$$R_0 = \frac{\beta(1-\varepsilon)(\mu+u_2)(\sigma+\eta+u_2+\mu)\delta}{(\mu+u_1+u_2)(\delta+\alpha+\mu)(\eta+\mu+\sigma)(\eta+\mu+\sigma+u_1+u_2)} \quad (25)$$

Stability analysis

In this section, a stability analysis will be carried out using the eigenvalues of the Jacobian matrix from the equilibrium point contained in the model. Eqs. 10 to 16 were tested for stability by substituting the disease-free equilibrium point and the endemic equilibrium point. Eqs. 10 to 16 are linearized using the Jacobian matrix using Eq. 26.

$$J(E) = \begin{bmatrix} u_1 - \beta(1-\varepsilon)i_1 - \mu & u_2 & 0 & 0 \\ u_1 & -u_2 - \mu & 0 & 0 \\ \beta(1-\varepsilon)i_1 & 0 & -\delta - \alpha - \mu & 0 \\ 0 & 0 & \delta & 0 \\ 0 & 0 & 0 & 0 \\ 0 & 0 & \alpha & 0 \\ 0 & 0 & 0 & 0 \end{bmatrix} \quad (26)$$

$$\begin{bmatrix} -\beta(1-\varepsilon)s_1 & 0 & 0 & \kappa_1 \\ 0 & 0 & 0 & \kappa_2 \\ \beta(1-\varepsilon)s_1 & 0 & 0 & 0 \\ -u_1 - \sigma - \eta - \mu & u_2 & 0 & 0 \\ u_1 & -u_2 - \sigma - \eta - \mu & 0 & 0 \\ \eta & \eta & -\gamma - \mu & 0 \\ \sigma & \sigma & \gamma & -\kappa_1 - \kappa_2 - \mu \end{bmatrix}$$

Substitute the parameter values in Table 2 and Eq. 17 into the $J(E)$ matrix. The eigenvalue matrix $J(E)$ has a non-zero solution if and only if $\det(J(E) - \lambda I)$ is called the characteristic equation. Then by substituting the parameter values contained in Table 2 to Eq. 26, then the R_0 value and the eigenvalues for the disease-free equilibrium point are obtained as in Table 3.

Based on the value of R_0 , it is obtained the value of $R_0 > 1$ and $R_0 < 1$. On the first R_0 , $R_0 > 1$ obtained because the individual level is vulnerable to physical distancing measures of 0.1, individuals who use masks 0.2 and individuals who stop/do not use masks 0.8 so that the disease spreads into an epidemic. On the second R_0 , $R_0 < 1$ obtained because the level of individuals who are vulnerable to physical distancing measures is 0.55, individuals who use masks are 0.55 and individuals who stop/do not use masks are 0.45 so that the disease will disappear within a certain time. On the last R_0 , $R_0 < 1$ obtained because the level of individuals who are vulnerable to physical distancing measures, individuals who use masks are 0.88 and individuals who stop/do not use masks are 0.12 so that the disease will disappear within a certain time. Therefore, the value of R_0 is very dependent on the parameters for controlling and preventing COVID-19 disease, namely physical distancing parameters, using masks, and stopping/not using masks. The more individuals who follow health protocols such as physical distancing measures and the use of masks and the fewer individuals who stop/not use masks, the smaller the R_0 value generated so that the disease will quickly disappear. Next, substitute the parameter values contained in Table 2 and Eq. 18 to $J(E)$ matrix. The eigenvalues of the endemic equilibrium points are shown in Table 4.

Simulation with several parameters

We illustrate the impact of the level of physical distancing measures at 0.1, individuals wearing masks at 0.2 and individuals stopping/not using masks at 0.8 as shown in Fig. 2.

The illustration uses a percentage of the total population N , so the overall results are expressed in percent. Fig. 2(a) shows that the rate of the subpopulation of vulnerable individuals not wearing masks continued to decline initially to 78%. The subpopulation of individuals who tend to use masks also decreased by 19.5%. The decrease occurs

Table 3: Eigenvalues and R_0 for the disease-free equilibrium point

1.	$\varepsilon = 0,1, u_1 = 0,2, u_2 = 0,8$	
	Eigenvalue	
	$\lambda_1 = -0.0000 + 0.0000i$	$\lambda_5 = +0.0257 + 0.0000i$
	$\lambda_2 = -1.0000 + 0.0000i$	$\lambda_6 = -0.0000 + 0.0000i$
	$\lambda_3 = -1.3175 + 0.0000i$	$\lambda_7 = -0.0715 + 0.0000i$
	$\lambda_4 = -0.6884 + 0.0000i$	<i>Unstable</i>
R_0		
$R_0 = 1.283142917$		
2.	$\varepsilon = 0,55, u_1 = 0,55, u_2 = 0,45$	
	Eigenvalue	
	$\lambda_1 = -1.0000 + 0.0000i$	$\lambda_5 = -0.1834 + 0.0000i$
	$\lambda_2 = -0.0000 + 0.0000i$	$\lambda_6 = -0.0000 + 0.0000i$
	$\lambda_3 = -1.3044 + 0.0000i$	$\lambda_7 = -0.0715 + 0.0000i$
	$\lambda_4 = -0.4924 + 0.0000i$	<i>Asymptotically stable</i>
R_0		
$R_0 = 0.4868007714$		
3.	$\varepsilon = 0,9, u_1 = 0,88, u_2 = 0,12$	
	Eigenvalue	
	$\lambda_1 = -1.0000 + 0.0000i$	$\lambda_5 = -0.2729 + 0.0000i$
	$\lambda_2 = -0.0000 + 0.0000i$	$\lambda_6 = -0.0000 + 0.0000i$
	$\lambda_3 = -1.2778 + 0.0000i$	$\lambda_7 = -0.0715 + 0.0000i$
	$\lambda_4 = -0.4293 + 0.0000i$	<i>Asymptotically stable</i>
R_0		
$R_0 = 0.07074610245$		

Table 4: The eigenvalues of the endemic equilibrium point

1.	$\varepsilon = 0,1, u_1 = 0,2, u_2 = 0,8$	
	Eigenvalue	
	$\lambda_1 = -0.0000 + 0.0000i$	$\lambda_5 = -0.0000 + 0.0010i$
	$\lambda_2 = -1.3113 + 0.0000i$	$\lambda_6 = -0.0000 + 0.0010i$
	$\lambda_3 = -0.6688 + 0.0000i$	$\lambda_7 = -0.0715 + 0.0000i$
	$\lambda_4 = -0.0000 + 0.0000i$	<i>Asymptotically stable</i>
2.	$\varepsilon = 0,55, u_1 = 0,55, u_2 = 0,45$	
	Eigenvalue	
	$\lambda_1 = -1.0000 + 0.0000i$	$\lambda_5 = -0.0000 + 0.0000i$
	$\lambda_2 = -1.4035 + 0.0000i$	$\lambda_6 = -0.0024 + 0.0000i$
	$\lambda_3 = -0.5766 + 0.0000i$	$\lambda_7 = -0.0715 + 0.0000i$
	$\lambda_4 = +0.0024 + 0.0000i$	<i>Unstable</i>
3.	$\varepsilon = 0,9, u_1 = 0,88, u_2 = 0,12$	
	Eigenvalue	
	$\lambda_1 = -0.9999 + 0.0000i$	$\lambda_5 = -0.0000 + 0.0000i$
	$\lambda_2 = -1.5770 + 0.0000i$	$\lambda_6 = -0.0030 + 0.0000i$
	$\lambda_3 = -0.4030 + 0.0000i$	$\lambda_7 = -0.0715 + 0.0000i$
	$\lambda_4 = +0.0031 + 0.0000i$	<i>Unstable</i>

because of the movement between subpopulations, so that the number of susceptible subpopulations decreases drastically without significant input from

population R. The susceptible subpopulations that do not use masks experience a greater decrease than the susceptible subpopulations that do not use

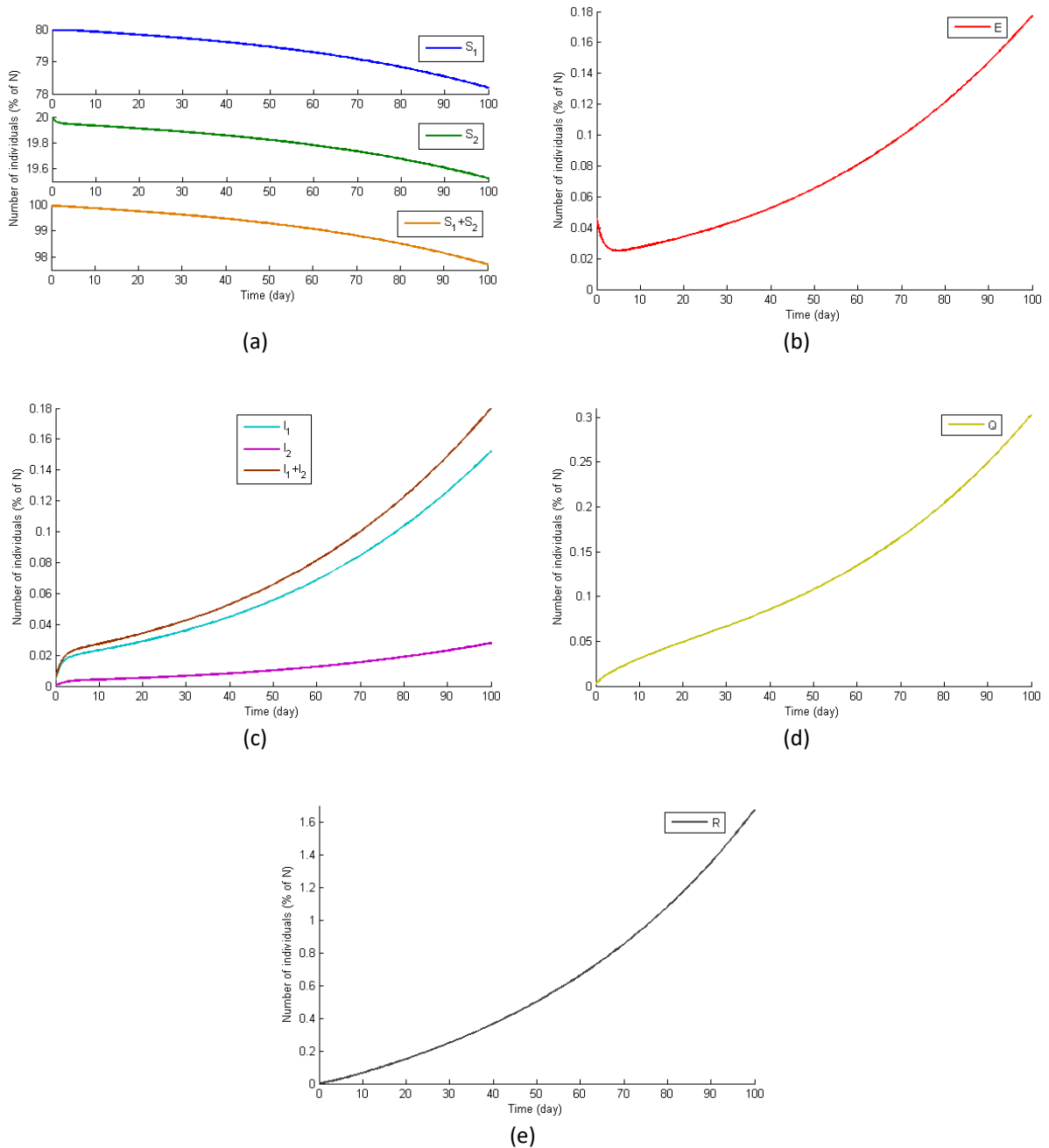

Fig. 2: The subpopulation of the spread of COVID-19 with $\varepsilon = 0.1, u_1 = 0.2, u_2 = 0.8$

masks, this is because the level of individuals who stop/do not use masks is 0.8, while the level of individuals who use masks is 0.2. The decline was exacerbated by the level of individuals taking physical distancing measures, which was only 0.1 so that the number of exposed individuals increased. In Fig. 2(b), the rate of the exposed population increased sharply by 0.18%, several times from the previous position. The graph had decreased due to the interaction of S1 and S2 that did not go to E. The increase was caused by the rate of individuals taking physical distancing measures of 0.1 and the displacement of the subpopulation into infected individuals due to the incubation period of the virus and quarantine individuals after being tested positive for COVID-19 through rapid, antigen, or swab tests. Fig. 2(c) shows the rate of the infected subpopulation not wearing a mask increased by 0.16%. The subpopulation of infected individuals who use masks also increases but the number is very small compared to those without masks. The increase occurred due to the movement between infected subpopulations so that the number of subpopulations increased in each subpopulation. This is because the level of individuals who stop/do not use masks is 0.8 while the level of individuals who use masks is 0.2. The input from exposed individuals is quite large, on the other hand the output to quarantined individuals is moderate. The decline was not very noticeable as there was very little movement of infected individuals receiving COVID-19 treatment and infected individuals who had recovered naturally from COVID-19 illness. Fig. 2(d) shows the rate at which the subpopulation of quarantined individuals increased by 0.3%. The increase in the karatina subpopulation was caused by the number of infected individuals who carried out the Swab Test or Rapid Test and the number of infected individuals who received treatment for COVID-19. The subpopulation decline was not seen as significant due to the large input of infected individuals. In Fig. 2(e), the rate of individual subpopulation recovering increased to 1.7%. The increase in the subpopulation was caused by the displacement of the subpopulation of infected individuals I_1 and I_2 who recovered naturally from COVID-19 disease and the displacement of the quarantine subpopulation Q who had recovered from COVID-19 disease with treatment.

This means that the disease will continue to exist and cause infection in the population. The study tries to illustrate the impact of the level of physical distancing measures by 0.55, individuals using masks at 0.55 and individuals stopping/not using masks at 0.45 as shown in Fig. 3. Fig. 3(a) shows that the level of susceptible subpopulations that do not use masks continues to increase, while the subpopulation of susceptible individuals who use masks decreases. The number of increases in S1 is not significant because the number of S2 is still larger, the implication is that the number of susceptible populations continues to increase. This positive trend was due to input from the recovered population, whereas the exposed population did not have a large transition. This is due to the interaction of S1 and S2 in a positive trend, while the susceptible to infected interaction is limited by the physical distancing parameter. Fig. 3(b) shows that the rate of the exposed population has decreased very significantly to close to 0.001% and the graph will move towards a point and be stable at that point until $t = \infty$. The decline was caused by the movement of the population to infected individuals due to the incubation period of the virus and quarantined individuals after being tested positive for COVID-19 through rapid tests, antigens, or swabs. In Fig. 3(c), the rate of the infected subpopulation that does not wear a mask has decreased very significantly, approaching 0.001% and the graph will move towards a point and be stable at that point until $t = \infty$. The subpopulation of infected individuals wearing masks experienced rapid changes where the graph dropped to 0.001% and the graph went to a point and was stable at that point until $t = \infty$. The decrease and increase occurred due to movement between subpopulations so that the number of subpopulations increased and decreased in each subpopulation. This is because the level of individuals who stop/do not use masks is 0.45 while the level of individuals who use masks is 0.55. The decline also occurred due to the movement of infected individuals who received COVID-19 treatment and infected individuals who had recovered naturally from COVID-19 disease. Fig. 3(d). In Fig. 3(d), the rate of the subpopulation of quarantined individuals changes rapidly where the graph drops to near 0% and towards a point and stabilizes at that point until $t = \infty$. The increase in the subpopulation was

caused by the number of exposed individuals who did the Swab Test or Rapid Test and the number of infected individuals who received treatment

for COVID-19 disease, while the decrease in the subpopulation was due to quarantined individuals who had recovered. COVID-19 disease. In Fig. 3(e),

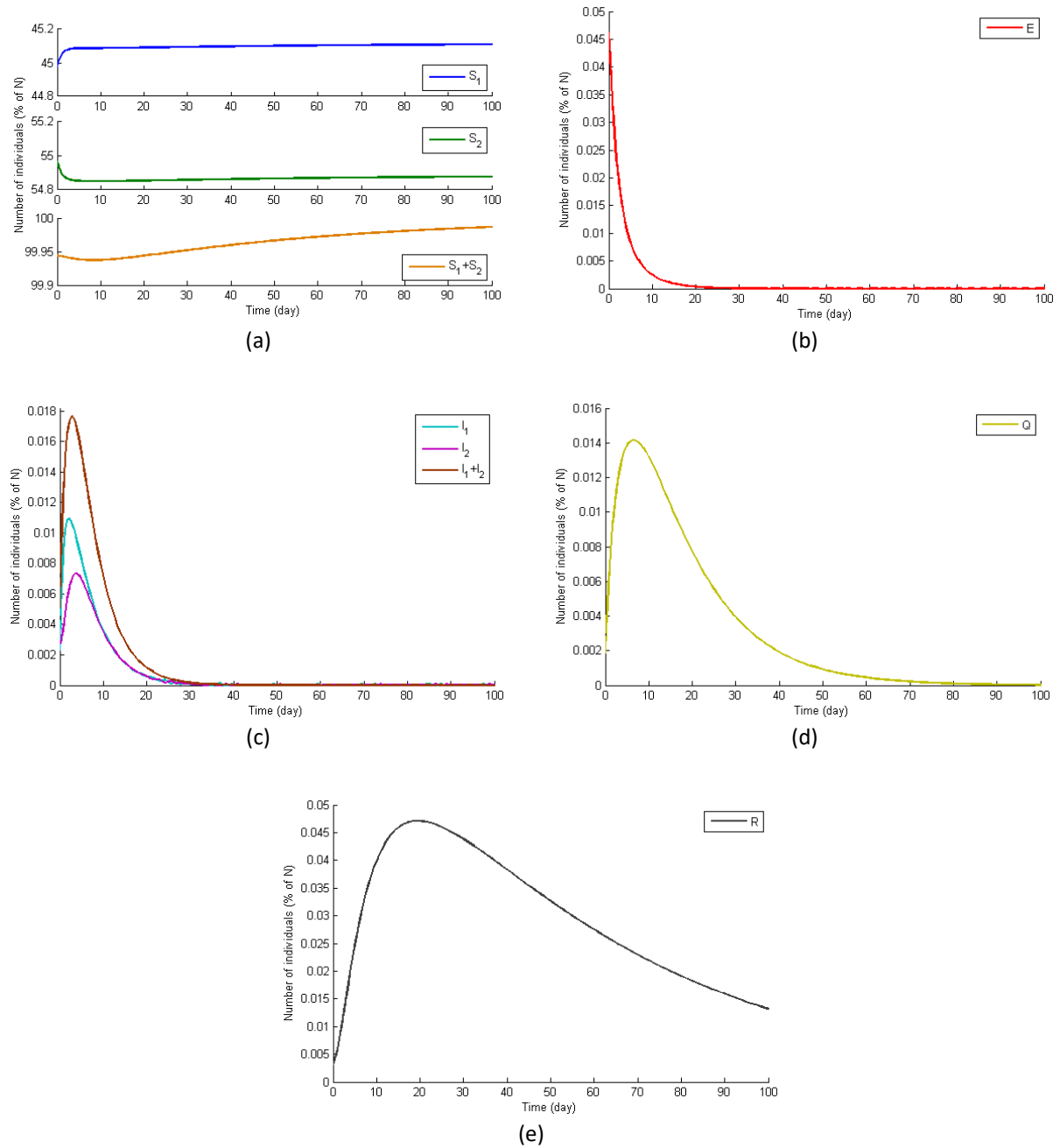

Fig. 3: The subpopulation of the spread of COVID-19 with $\varepsilon = 0.55, u_1 = 0.55, u_2 = 0.45$

the rate of individual subpopulations recovering increased to 0.046%. Then the graph begins to descend towards a point and stabilizes at that point

until $t = \infty$. The increase in the subpopulation was caused by the displacement of the subpopulation of infected individuals I_1 and I_2 who recovered naturally

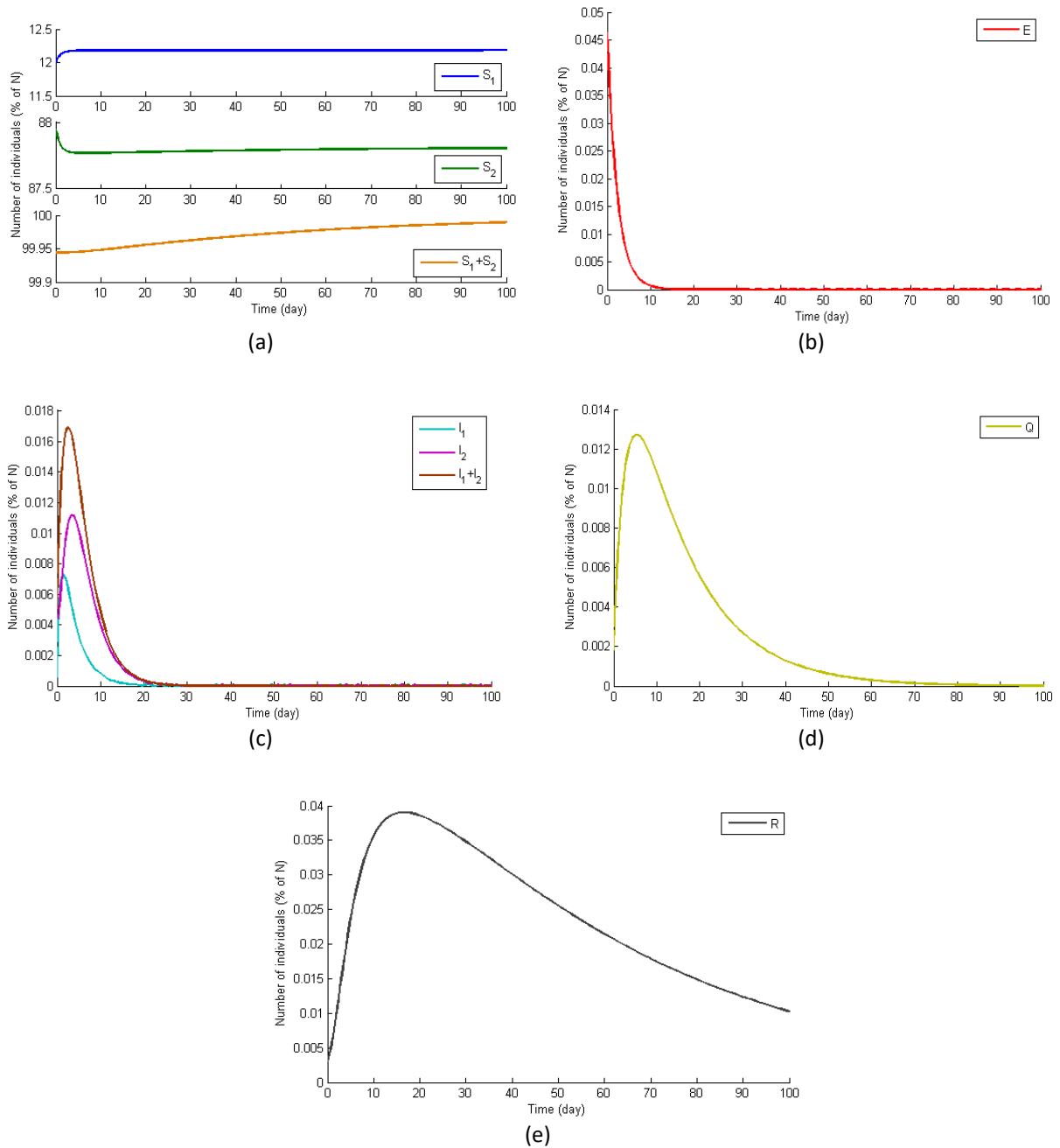

Fig. 4: The subpopulation spread of COVID-19 with $\varepsilon = 0.9, u_1 = 0.88, u_2 = 0.12$

from COVID-19 disease and the displacement of the quarantine subpopulation Q who had recovered from COVID-19 disease with treatment. This means that the disease does not spread to the population and the disease will disappear over time.

The simulation shows the impact of the level of physical distancing measures is 0.9, individuals who use masks are 0.88 and individuals who stop/do not use masks are 0.12 as in Fig. 4. In the simulation with these parameters, the resulting shapes and transitions are the same as the simulations in the level of physical distancing measures by 0.55, individuals using masks at 0.55 and individuals stopping/not using masks at 0.45.

Figs. 3 and 4 have the same shape and show the stability of the simulation. Fig. 4(a) has a different starting point, while the shape of the curve continues to increase the susceptible population. This happens because the designed optimistic formula has succeeded in avoiding individuals from being in other populations/subpopulations. Figs. 4(b) and 4(c) only change in the momentum of the increase and decrease in the number of individuals. The same thing happened to the quarantine and recovery population in Figs. 4(d) and 4(e). From the simulations that have been carried out, the shape of the curve for each case can be different if it has not reached the peak point in the exposed population, infected population, and quarantine population. It takes a very long time to break up the peak of the disease. With optimistic parameters of more than 0.55 physical distancing and the use of masks, a peak curve has emerged and stability is obtained. Individuals are concentrated in the susceptible population/subpopulation and recovered population. By maintaining this number and implementing longer compliance, individuals in the exposed, infected, and quarantined populations are depleted to the recovered population. Parameters that play a role in preventing infection in the susceptible population are u_1 and u_2 . These two parameters exclude all individuals into the masked susceptibility subpopulation because the assumption is made that this subpopulation cannot be infected. Looking at the simulations in Figs. 3 and 4, a significant parameter is physical distancing. This parameter plays a role in accelerating and slowing the transition of susceptible individuals to other populations. When the parameter is increased,

peak momentum is achieved faster, and vice versa. This parameter affects the exposed population, infected subpopulation, quarantine population, and a small part of the recovered population. Based on the illustration results, it can be seen that the more individuals who take physical distancing measures, use masks and the fewer individuals who stop/do not use masks, the spread of COVID-19 will be smaller so that in a certain time the disease will disappear. COVID-19 disease control measures do not only focus on physical distancing and the use of masks, but this is one of the most important steps taken as stated by WHO. There are many other precautions that can minimize the spread. The more preventive measures are taken, the faster the disease will disappear, one of which is if the detection/tracking of individuals who have been infected and exposed to COVID-19 is increased, the individual will receive treatment faster so that fewer people will contract the disease.

CONCLUSION

This study proposes a mathematical model of COVID-19 spread that takes into account people's behavior and compliance. The use of masks and physical distancing are among the behaviors under consideration. This behavior divides the susceptible population into two subpopulations: those who use a mask and those who do not use a mask. The same holds true for the infected population. Using a mask, the value of the compliance parameter is set between 0 and 1. The physical distancing compliance parameter, which ranges from 0 to 1, does not divide the population. The analysis was performed for two different equilibrium points: disease-free equilibrium and endemic equilibrium. The equilibrium point is obtained from the position where there is no change in the number of individuals in the population. Disease-free equilibrium means that there is no disease in the population, while endemic equilibrium is that there are infected subpopulations in the population. For both equilibrium points, the stability criterion is asymptotically stable. Disease-free conditions are met and maintained if compliance with masks and physical distance exceeds 55%. Based on the stability of the disease endemic balance point, this condition will become endemic in an area/community if mask compliance is less than 20% and physical distance from crowds

is not maintained. The basic reproduction rate has a significant impact on the presence or absence of an endemic in a population. The model illustration shows that if the rate of people wearing masks is at least 55% and the rate of people taking physical distance measures is at least 55%, the COVID-19 disease will be eradicated from the population within a certain time frame. The spread of COVID-19 will be significantly reduced if the awareness level of people wearing masks is increased to 88% and the level of people taking physical distancing measures is increased to 90%. As a result, the disease is vanishing from the population at a faster rate. The measures are intended to increase by 55%-88% the masked subpopulation of susceptible and infected people. This policy must be implemented because it demonstrates a positive trend of disease-free status in a relatively short period of time. Physical distancing adherence has increased from 55% to 90%, indicating a positive trend toward COVID-19 extinction. Mask pollution can be dealt with quickly based on the time it takes to be disease-free. Policy decisions involving masks for specific populations, on the other hand, should be reconsidered. It can be researched using pharmaceutical solutions that do not generate a lot of medical waste. The long-term solution to eradicating COVID-19 is to include other parameters, such as those for increasing and decreasing the number of wards, outpatient solutions, and parameters related to the internet of things (IoT). COVID-19 must be eradicated as soon as possible in order to reduce the environmental impact of mask waste.

AUTHOR CONTRIBUTIONS

M. Ramli performed the literature review, running the model, analyzed and interpreted the data, prepared the manuscript text, and manuscript edition. M. Mukramati performed the literature review, running the model, analyzed and interpreted the data, prepared the manuscript text, and manuscript edition. M. Ikhwan performed the literature review, prepared numerical code, prepared the manuscript text, and manuscript edition. H. Hafnani performed the literature review, analyzed and interpreted the data, prepared the manuscript text, and manuscript edition. All authors agreed on the final version of the manuscript.

ACKNOWLEDGEMENT

The authors would like to thank the editors and anonymous referees who provided fruitful and crucial feedback on our manuscript.

CONFLICT OF INTEREST

The authors declare no potential conflict of interest regarding the publication of this work. In addition, the ethical issues including plagiarism, informed consent, misconduct, data fabrication and, or falsification, double publication and, or submission, and redundancy have been completely witnessed by the authors.

OPEN ACCESS

This article is licensed under a Creative Commons Attribution 4.0 International License, which permits use, sharing, adaptation, distribution and reproduction in any medium or format, as long as you give appropriate credit to the original author(s) and the source, provide a link to the Creative Commons license, and indicate if changes were made. The images or other third party material in this article are included in the article's Creative Commons license, unless indicated otherwise in a credit line to the material. If material is not included in the article's Creative Commons license and your intended use is not permitted by statutory regulation or exceeds the permitted use, you will need to obtain permission directly from the copyright holder. To view a copy of this license, visit: <http://creativecommons.org/licenses/by/4.0/>

PUBLISHER'S NOTE

GJESM Publisher remains neutral with regard to jurisdictional claims in published maps and institutional affiliations.

ABBREVIATIONS

α	The rate of individual exposed to quarantine individual
β	Disease transmission rate
COVID-19	Coronavirus Disease 2019
δ	The rate of individual is exposed to an infected individual

det	Determinant		Number of subpopulations of susceptible individuals not wearing masks
ε	<i>physical distancing</i>		
η	The rate of infected individuals being quarantined individuals	S_2	Number of subpopulations of susceptible individuals using masks
E	Number of individual subpopulations exposed	<i>SARS-Cov2</i>	Severe acute respiratory syndrome coronavirus 2
E_0	Disease-free equilibrium point	<i>SEIQR</i>	susceptible-exposed-infected-quarantine-recovery
E_1	Endemic equilibrium point	<i>SEIR</i>	susceptible-exposed-infected-recovery
<i>Eq. / Eqs.</i>	Equation / equations	T	Time
<i>Fig.</i>	Figure	u_1	Mask usage rate
γ	The rate of quarantine individuals recovers with treatment	u_2	The rate of not/stopping using a mask
	Identity matrix	φ	The new infection rate
I_1	Number of subpopulations of infected individuals not wearing masks	<i>WHO</i>	World Health Organization
I_2	Number of subpopulations of infected individuals wearing masks	ζ	The infection transition rate
J	Jacobian matrix	x	State variable
K	Spectral radius matrix		
λ	Eigenvalue		
κ_1	The rate of recovered individual back to susceptible not wearing masks		
κ_2	The rate of recovered individual back to susceptible wearing masks		
μ	The birth or death rate of individuals in the population		
M	meter		
<i>MERS-CoV</i>	Middle East Respiratory Syndrome Coronavirus		
N	Total population in the system		
<i>N95</i>	Not resistant to oil with 95% particle filtered		
%	Percent		
Q	Number of quarantined individual subpopulations		
R	Number of subpopulations of recovered individuals		
σ	The rate of infected individuals recovers without treatment		
S	Number of subpopulations of susceptible individuals		

REFERENCES

Arslan, M.; Xu, B.; El-Din, M.G., (2020). Transmission of SARS-CoV-2 via fecal-oral and aerosols-borne routes: Environmental dynamics and implications for wastewater management in underprivileged societies. *Sci. Total Environ.*, 743: 140709 (7 pages).

Batistela, C.M.; Correa, D.P.F.; Bueno, A.M.; Piqueira, J.B.C., (2021). SIRSi compartmental model for COVID-19 pandemic with immunity loss. *Chaos Solit. Fractals*, 142: 110338 (12 pages).

Bagepally, B.S.; Haridoss, M.; Natarajan, M.; Jeyashree, K.; Ponnaiah, M., (2021). Cost-effectiveness of surgical mask, N-95 respirator, hand-hygiene and surgical mask with hand hygiene in the prevention of COVID-19: Cost effectiveness analysis from Indian context. *Clin. Epidemiol. Global Health*. 10: 100702 (8 pages).

Chintalapudi, N.; Battineni, G.; Amenta, F., (2020). COVID-19 virus outbreak forecasting of registered and recovered cases after sixty day lockdown in Italy: A data driven model approach. *J. Microbiol. Immunol. Infect.*, 53(3): 396-403 (8 pages).

Driessche, K.V.; Hens, N.; Tilley, P.; Quon, B.S.; Chilvers, M.A.; de Groot, R.; Cotton, M.F.; Marais, B.J.; Spreet, D.P.; Zlosnik, J.E., (2015). Surgical masks reduce airborne spread of *Pseudomonas aeruginosa* in colonized patients with cysticfibrosis. *Am. J. Respir. Crit. Care Med.*, 192(7): 897-899 (3 pages).

Driessche, P.; Watmough, J., (2002). Reproduction numbers and sub-threshold endemic equilibria for compartmental models of disease transmission. *Math. Biosci.*, 180(1-2): 29-48 (20 pages).

Doremalen, N.; Bushmaker, T.; Morris, D.H.; Holbrook, M.G.; Gamble, A.; Williamson, B.N.; Tamin, A.; Harcourt, J.L.;

- Thornburg, N.J.; Gerber, S.I.; Lloyd-Smith, J.O.; de Wit, E.; Munster, V.J., (2020). Aerosol and surface stability of HCoV-19 (SARS-CoV-2) compared to SARS-CoV-1. *N. Engl. J. Med.*, 382(16): 1564–1567 (4 pages).
- Dwomoh, D.; Iddi, S.; Adu, B.; Aheto, J.M.; Sedzro, K.M.; Fobil, J.; Bosomprah, S., (2021). Mathematical modeling of COVID-19 infection dynamics in Ghana: Impact evaluation of integrated government and individual level interventions. *Infect. Dis. Model.*, 6: 381–397 (17 pages).
- Eikenberry, S.E.; Mancuso, M.; Iboi, E.; Phan, T.; Eikenberry, K.; Kuang, Y.; Kostelich, E.; Gumel, A.B., (2020). To mask or not to mask: Modeling the potential for face mask use by the general public to curtail the COVID-19 pandemic. *Infect. Dis. Model.*, 5: 293–308 (16 pages).
- Eubank, S.; Eckstrand, I.; Lewis, B.; Venkatramanan, S.; Marathe, M.; Barrett, C.L., (2020). Commentary on Ferguson, et al., “Impact of non-pharmaceutical interventions (NPIs) to reduce COVID-19 mortality and healthcare demand”. *Bull. Math. Biol.*, 82: 52 (7 pages).
- Ferguson, N.; Laydon, D.; Nedjati-Gilani, G.; Imai, N.; Ainslie, K.; Baguelin, M.; Bhatia, S.; Boonyasiri, A.; Cucunuba Perez, Z.; Cuomo-Dannenburg, G.; Dighe, A.; Dorigatti, I.; Fu, H.; Gaythorpe, K.; Green, W.; Hamlet, A.; Hinsley, W.; Okell, L.; Van Elsland, S.; Thompson, H.; Verity, R.; Volz, E.; Wang, H.; Wang, Y.; Walker, P.; Walters, C.; Winskill, P.; Whittaker, C.; Donnelly, C.; Riley, S.; Ghani, A., (2020). Impact of nonpharmaceutical interventions (NPIs) to reduce COVID-19 mortality and healthcare demand. Report, Imperial College London. UK.
- Garnett, C.; Jackson, S.; Oldham, M.; Brown, J.; Steptoe, A.; Fancourt, D., (2021). Factors associated with drinking behaviour during COVID-19 social distancing and lockdown among adults in the UK. *Drug Alcohol Depend.*, 219: 108461 (8 pages).
- Harapan, H.; Itoh, N.; Yufika, A.; Winardi, W.; Keam, S.; Te, H.; Megawati, D.; Hayati, Z.; Wagner, A.L.; Mudatsir, M., (2020). Coronavirus disease 2019 (COVID-19): A literature review. *J. Infect. Public Health*, 13(5): 667–673 (7 pages).
- Kojima, M.; Iwasaki, F.; Johannes, H.P.; Edita, E.P., (2020). Strengthening waste management policies to mitigate the COVID-19 pandemic. *Econ. Res. Instit.*, 5: 1-4 (4 pages).
- Li, G.; De Clercq, E., (2020). Therapeutic options for the 2019 novel coronavirus (2019-nCoV). *Nat. Rev. Drug Discov.*, 19(3): 149–150 (2 pages).
- Lin, Y.H.; Liu, C.H.; Chiu, Y.C., (2020). Google searches for the keywords of “wash hands” predict the speed of national spread of COVID-19 outbreak among 21 countries. *Brain Behav. Immun.*, 87: 30–32 (3 pages).
- Lo, S.; Lin, C.; Hung, C.; He, J.; Lu, P., (2021). The impact of universal face masking and enhanced hand hygiene for COVID-19 disease prevention on the incidence of hospital-acquired infections in a Taiwanese hospital. *Int. J. Infect. Dis.*, 104: 15-18 (4 pages).
- Lyu, W.; Wehby, G.L., (2020). Community use of face masks and COVID-19: Evidence from a natural experiment of state mandates in the US. *Health Aff.*, 39(8): 1419-1425 (7 pages).
- MacIntyre, C.R.; Nguyen, P.; Chughtai, A.A.; Trent, M.; Gerber, B.; Steinhofel, K.; Seale, H., (2021). Mask use, risk-mitigation behaviours and pandemic fatigue during the COVID-19 pandemic in five cities in Australia, the UK and USA: A cross-sectional survey. *Int. J. Infect. Dis.*, 106: 199-207 (9 pages).
- Manaqib, M.; Fauziah, I.; Mujiyanti, M., (2019). Mathematical model for MERS-COV disease transmission with medical mask usage and vaccination. *In Prime*, 1(2): 97–109 (13 pages).
- Mandal, M.; Jana, S.; Nandi, S.K.; Khatua, A.; Adak, S.; Kar, T.K., (2020). A model based study on the dynamics of COVID-19: Prediction and control. *Chaos Solit. Fractals*, 136: 109889 (12 pages).
- Phan, L.T.; Nguyen, T.V.; Luong, Q.C.; Nguyen, T.V.; Nguyen, H.T.; Le, H.Q.; Nguyen, T.T.; Cao, T.M.; Pham, Q.D., (2020). Importation and human-to-human transmission of a novel coronavirus in Vietnam. *N. Engl. J. Med.*, 382(9): 872-874 (3 pages).
- Resmawan, R.; Nuha, A.R.; Yahya, L., (2021). Analisis dinamika model transmisi COVID-19 dengan melibatkan intervensi karantina. *Jambura J. Math.*, 3(1): 66–79 (14 pages).
- Safitri, E.; Tarmizi, T.; Ramli, M.; Wahyuni, S.; Ikhwan, M., (2019). Model of virus therapy and chemotherapy for cancer. *IOP Conf. Ser.: Earth Environ. Sci.*, 364: 012029 (6 pages).
- Sasmita, N.R.; Ikhwan, M.; Suyanto, S.; Chongsuvivatwong, V., (2020). Optimal control on a mathematical model to pattern the progression of coronavirus disease 2019 (COVID-19) in Indonesia. *Global Health Res. Policy*, 5: 38 (12 pages).
- Satgas, (2021). Pasien Sembuh Terus Meningkatkan Mencapai 1.810.136 Orang.
- Soewono, E., (2020). On the analysis of Covid-19 transmission in Wuhan, Diamond Princess and Jakarta-cluster. *Commun. Biomath. Sci.*, 3(1): 9-18 (10 pages).
- Stockwell, R.E.; Wood, M.E.; He, C.; Sherrard, L.J.; Ballard, E.L.; Kidd, T.J.; Johnson, G.R.; Knibbs, L.D.; Morawska, L.; Bell, S.C., (2018). Face masks reduce the release of *Pseudomonas aeruginosa* cough aerosols when worn for clinically relevant periods. *Am. J. Respir. Crit. Care Med.*, 198(10): 1339-1342 (4 pages).
- Tang, B.; Bragazzi, N.L.; Li, Q.; Tang, S.; Xiao, Y.; Wu, J., (2020). An updated estimation of the risk of transmission of the novel coronavirus (2019-nCoV). *Infect. Dis. Model.*, 5: 248–255 (8 pages).
- Tran, T.T.; Pham, L.T.; Ngo, Q.X., (2020). Forecasting epidemic spread of SARS-CoV-2 using ARIMA model (case study: Iran). *Global J. Environ. Sci. Manage.*, 6: 1–10 (10 pages).
- WHO, (2020a). Transmission of SARS-CoV-2: implications for infection prevention precautions. Jenewa, Swiss. World Health Organization.
- WHO, (2020b). Advice on the use of masks in the context of COVID-19. Jenewa, Swiss. World Health Organization.
- WHO, (2021a). Coronavirus disease (COVID-19) pandemic. World Health Organization.
- WHO, (2021b). Corona Virus Disease (COVID-19) Dashboard. World Health Organization.
- Wilder-Smith, A.; Freedman, D.O., (2020). Isolation, quarantine, social distancing and community containment: Pivotal role for old-style public health measures in the novel coronavirus (2019-nCoV) outbreak. *J. Travel Med.*, 27(2): 1–4 (4 pages).
- Zhu, C.C.; Zhu, J., (2021). Dynamic analysis of a delayed COVID-19 epidemic with home quarantine in temporal-spatial heterogeneous via global exponential attractor method. *Chaos Solit. Fractals*, 143: 110546 (15 pages).

AUTHOR (S) BIOSKETCHES

Ramli, M., Ph.D., Professor, Department of Mathematics, Universitas Syiah Kuala, Banda Aceh 23111, Indonesia.

Email: marwan.math@unsyiah.ac.id

ORCID: [0000-0003-1225-9063](https://orcid.org/0000-0003-1225-9063)

Mukramati, M., M.Sc. Student, Assistant Professor, Department of Mathematics, Universitas Syiah Kuala, Banda Aceh 23111, Indonesia.

Email: mukramatimhammad50@gmail.com

ORCID: [0000-0002-4125-6948](https://orcid.org/0000-0002-4125-6948)

Ikhwan, M., Ph.D., Candidate, Assistant Professor, Graduate School of Mathematics and Applied Sciences, Universitas Syiah Kuala, Banda Aceh 23111, Indonesia.

Email: m.ikhwan@mhs.unsyiah.ac.id

ORCID: [0000-0002-8162-1479](https://orcid.org/0000-0002-8162-1479)

Hafnani, H., M.Sc., Associate Professor, Department of Mathematics, Universitas Syiah Kuala, Banda Aceh 23111, Indonesia.

Email: hafnani@unsyiah.ac.id

ORCID: [0000-0003-0741-8904](https://orcid.org/0000-0003-0741-8904)

HOW TO CITE THIS ARTICLE

Ramli, M.; Mukramati, M.; Ikhwan, M.; Hafnani, H., (2022). Community behavior for mathematical model of coronavirus disease 2019 (COVID-19). *Global J. Environ. Sci. Manage.*, 8(2): 151-168.

DOI: [10.22034/gjesm.2022.02.01](https://doi.org/10.22034/gjesm.2022.02.01)

url: https://www.gjesm.net/article_245815.html

